

# Color Controller E-810 (G940)

## Color Controller E-810 (G940)

### PARTS CATALOG

This catalog gives the numbers and names of parts on this machine.

### CONTENTS

1.Color Controller (G940) .....	2
2.Cables & Documentations (G940).....	4
3.Options (G940-07/G928-01).....	6
<b>Parts Index</b> .....	<b>9</b>

July ,20 ' 2001

# 1. Color Controller (G940)

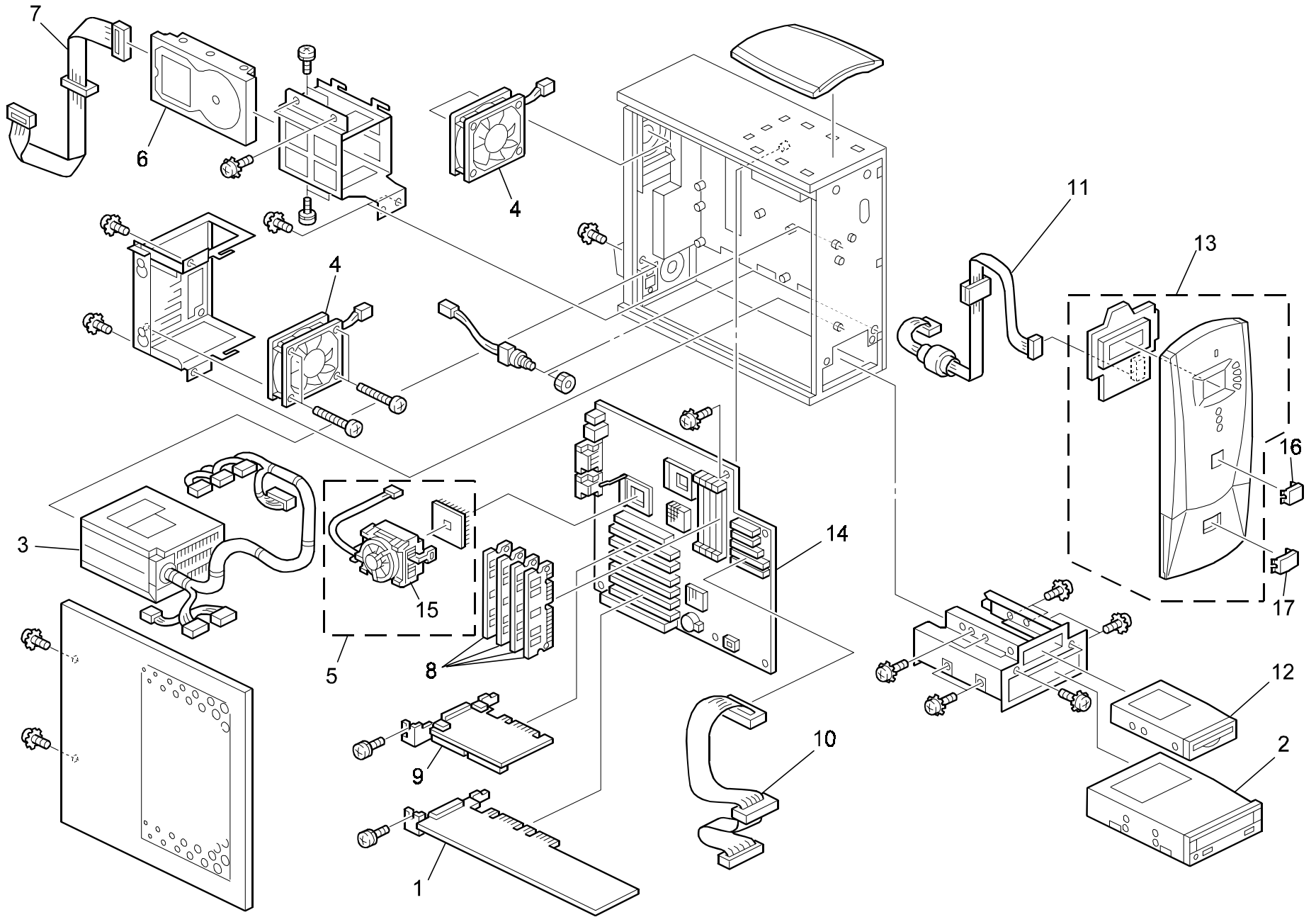

### 1.Color Controller (G940)

Index No.	Part No.	Description	Q'ty Per Assembly
1	G925 5007	Video Board	1
2	G925 5009	CD Drive	1
3	G925 5011	Power Supply	1
4	G925 5012	Chassis Fan	2
5	G940 5001	CPU With Fan	1
6	G940 5010	40GB IDE HDD	1
7	G940 5011	HDD IDE Cable	1
8	G940 5020	128MB DIMM	4
9	G940 5031	PCI Card ATA	1
10	G940 5034	IDE Cable For CD/ZIP	1
11	G940 5035	UIB Cable	1
12	G940 5053	ZIP 250MB Drive	1
13	G940 5136	Front Cover Ass'y	1
14	G940 5156	Mother Board	1
15	G940 9051	Fan For CPU	1
16	G940 5060	Fiery Jewel (20 pcs)	1
17	G940 5063	E-810 Jewel (20 pcs)	1

Index No.	Part No.	Description	Q'ty Per Assembly

## 2.Cables & Documentations (G940)

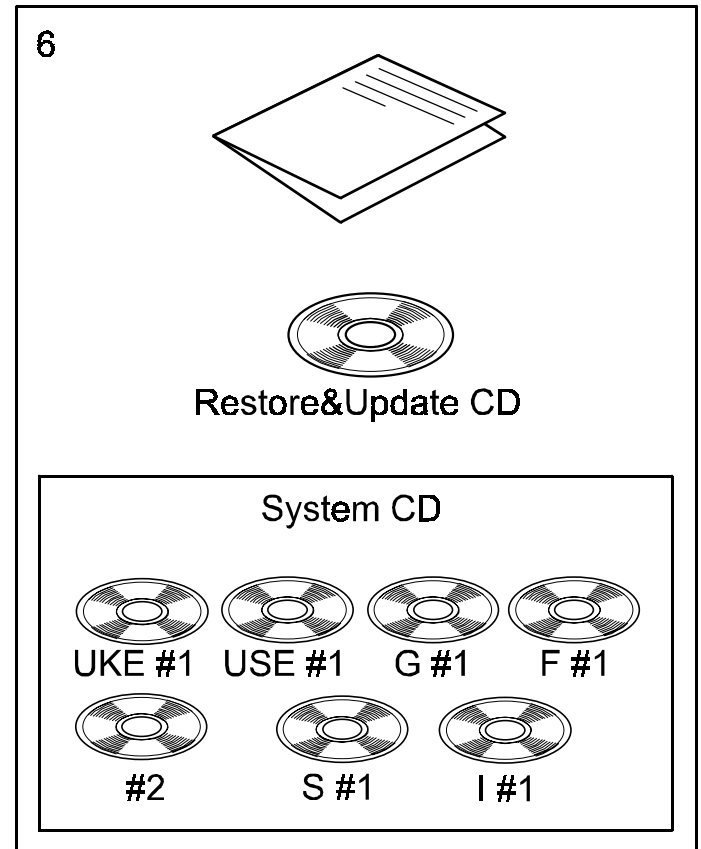
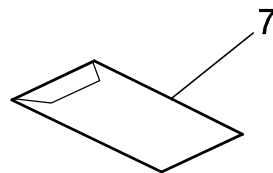
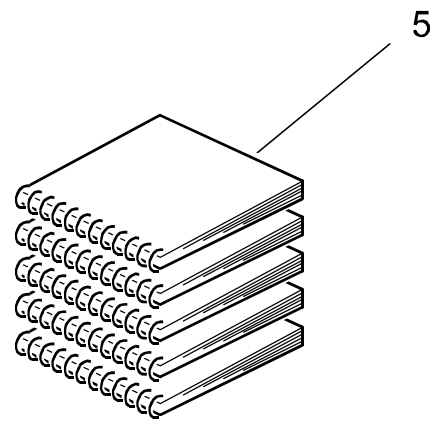
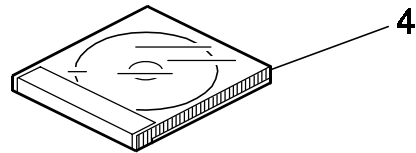
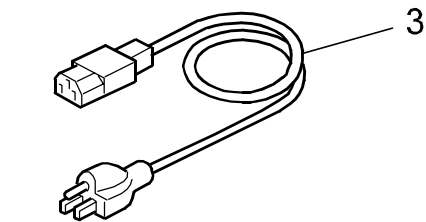
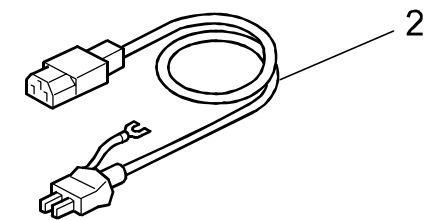
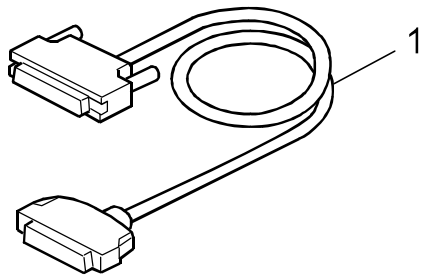

## 2.Cables & Documentations (G940)

Index No.	Part No.	Description	Q'ty Per Assembly
1	G925 5020	Copier I/F Cable	1
2	A747 5031	Power Supply Cord 115V	1
3	A747 5032	Power Supply Cord 230V	1
4	G940 5099	User Software CD	1
5	G940 5090	DOC Pack (English)	1
6	G940 9500	Service Kit	1
7	A747 5282	Grayscale Strip	1

Index No.	Part No.	Description	Q'ty Per Assembly

### 3.Options (G940-07/G928-01)

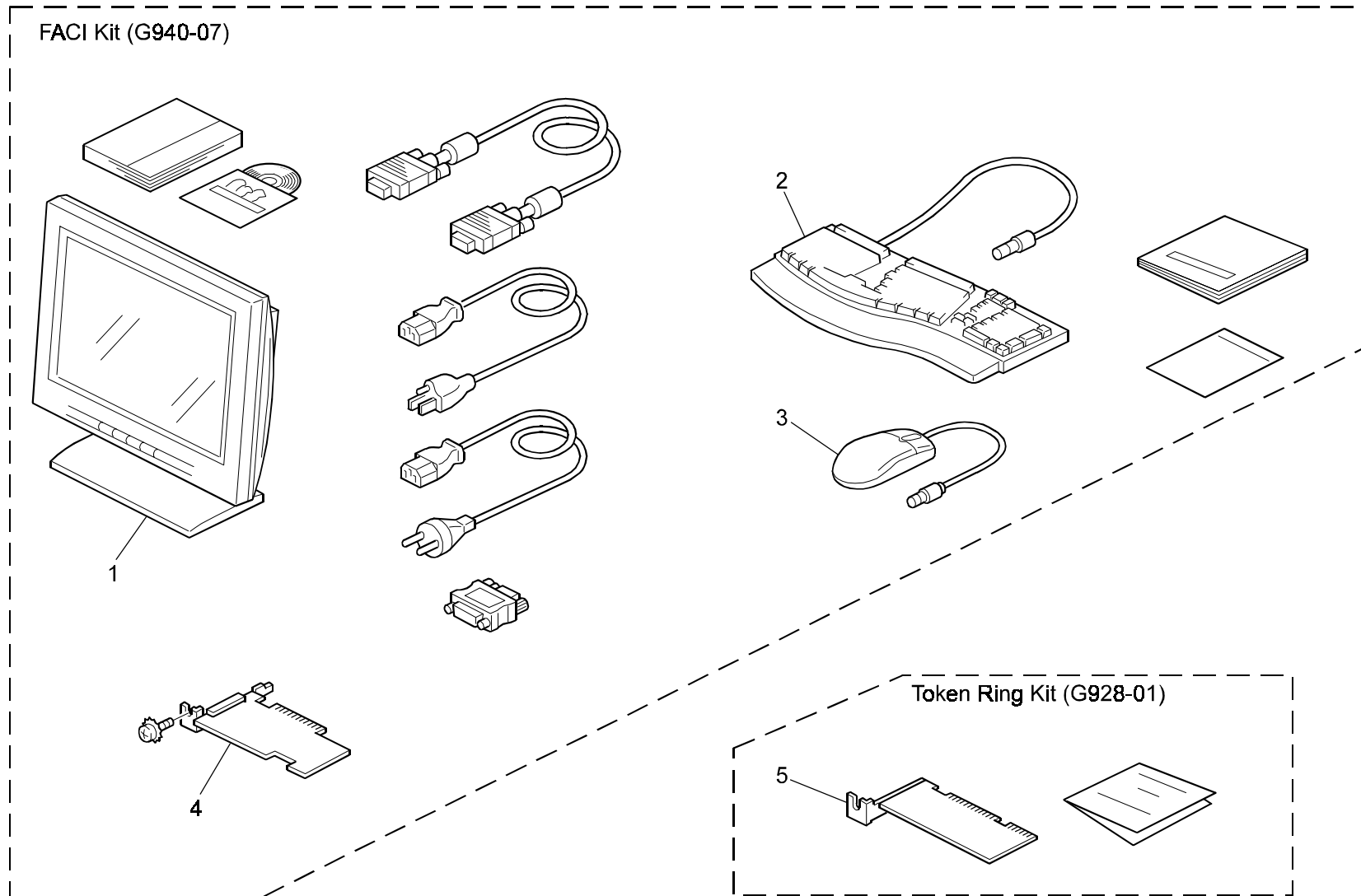

### 3.Options (G940-07/G928-01)

Index No.	Part No.	Description	Q'ty Per Assembly
1	G925 1002	FACI, Keyboard	1
2	G925 1003	FACI, 15" Flat Panel Monitor	1
3	G925 1001	FACI, Mouse	1
4	G940 0621	AGP Video Board	1
5	G925 5906	Token Ring Card	1

Index No.	Part No.	Description	Q'ty Per Assembly
-----------	----------	-------------	-------------------



# Parts Index

## Parts Index

Part No.	Description	Page and Index No.
G940 0621	AGP Video Board	7- 4
G940 5001	CPU With Fan	3- 5
G940 5010	40GB IDE HDD	3- 6
G940 5011	HDD IDE Cable	3- 7
G940 5020	128MB DIMM	3- 8
G940 5031	PCI Card ATA	3- 9
G940 5034	IDE Cable For CD/ZIP	3- 10
G940 5035	UIB Cable	3- 11
G940 5053	ZIP 250MB Drive	3- 12
G940 5060	Fiery Jewel (20 pcs)	3- 16
G940 5063	E-810 Jewel (20 pcs)	3- 17
G940 5090	DOC Pack (English)	5- 5
G940 5099	User Software CD	5- 4
G940 5136	Front Cover Ass'y	3- 13
G940 5156	Mother Board	3- 14
G940 9051	Fan For CPU	3- 15
G940 9500	Service Kit	5- 6

Part No.	Description	Page and Index No.
G925 1001	FACI, Mouse	7- 3
G925 1002	FACI, Keyboard	7- 1
G925 1003	FACI, 15" Flat Panel Monitor	7- 2
G925 5007	Video Board	3- 1
G925 5009	CD Drive	3- 2
G925 5011	Power Supply	3- 3
G925 5012	Chassis Fan	3- 4
G925 5020	Copier I/F Cable	5- 1
G925 5906	Token Ring Card	7- 5
A747 5031	Power Supply Cord 115V	5- 2
A747 5032	Power Supply Cord 230V	5- 3
A747 5282	Grayscale Strip	5- 7